



TEXAS

KAMINOFEN

JUSTUS

A+

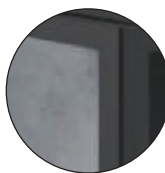

(1)



2

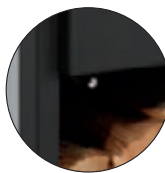

3

- 1** Erhältlich in der Ausführung:
(1) Specksteinkeramik, Korpus Stahl Schwarz
- 2** Luftdurchströmter Griff
- 3** Getrennt regelbare Primär- und Sekundärluft

Serienmäßiger Lieferumfang

- Luftdurchströmter Griff

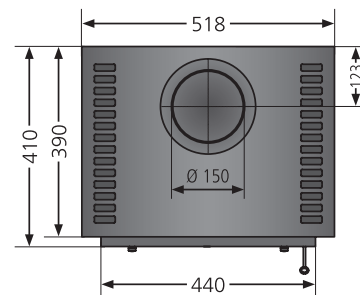
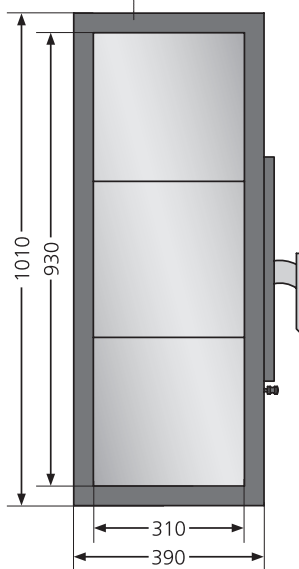
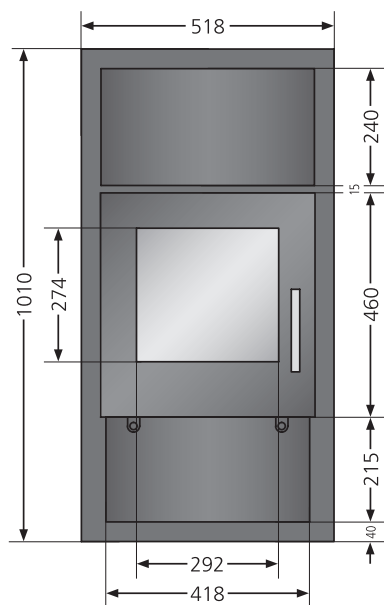

Erhältlich in der Ausführung	Best.Nr.	EAN-Code
Texas Specksteinkeramik, Korpus Stahl Schwarz	8358 22	4250340909242
Energieeffizienzklasse		A+
Anschlussmöglichkeit		oben
Nennwärmeleistung	kW	6,0
Gewicht (inkl. Verpackung)	kg	98
Raumheizvermögen bis	m ³	124
Länge Holzscheite	cm	30
Abgasmassenstrom	g/s	7,3
Abgastemperatur	°C	231
erforderlicher Förderdruck	mbar	0,12