

CABINET CISTERN

Sensor-flush with glass front

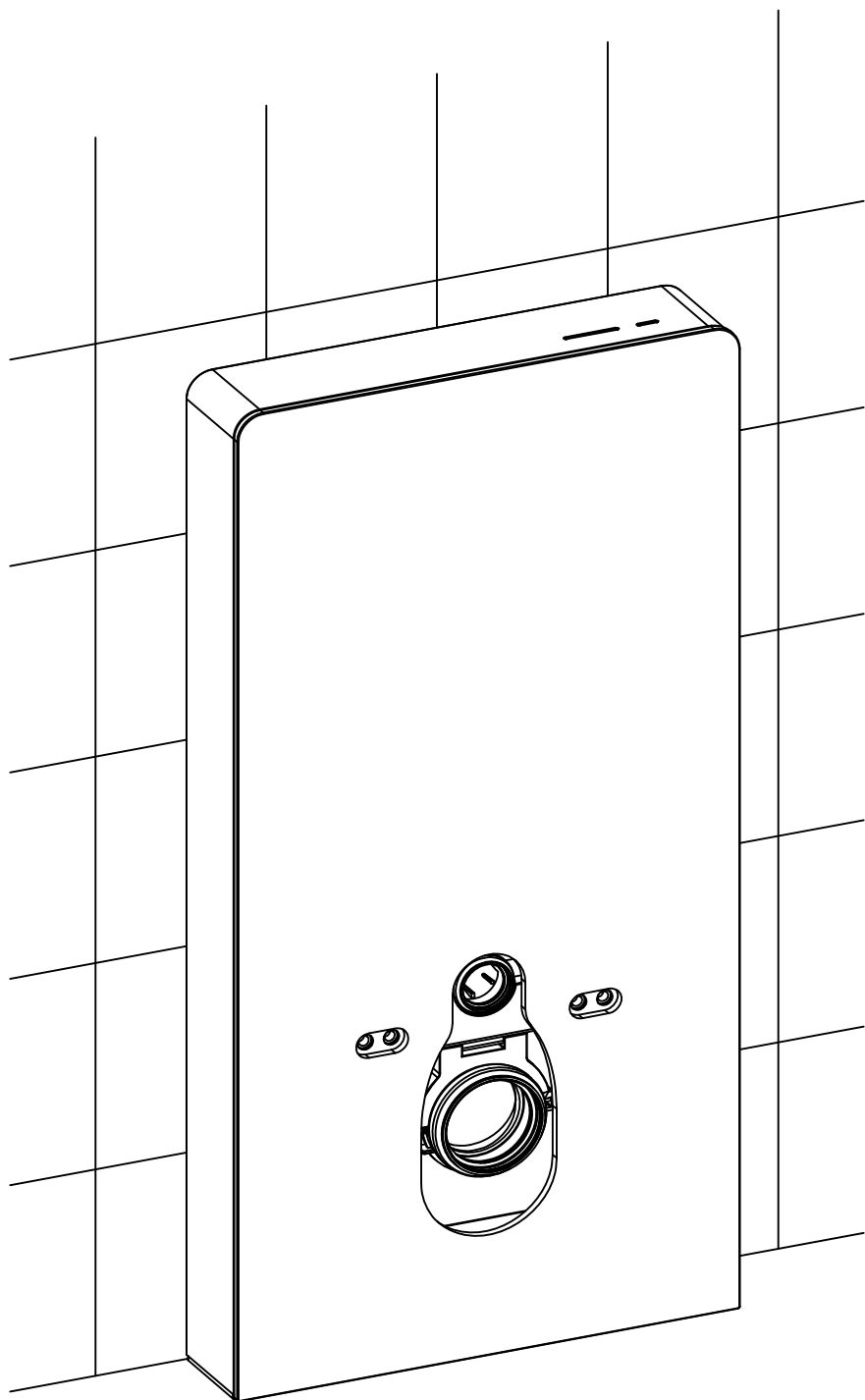

























INSTALLATION INSTRUCTIONS

Content

- Item list 2
- Technical specifications..... 4
- Technical drawing, inlet system & drainage system 5
- Installation..... 6
- Maintenance & daily care 14
- Warranty 20

Item List

Item List	Names	Specification	Quantity	Item List	Names	Specifications	Quantity
	rubber seal	ø110	1		expansion nut	SX10 ø6-8	2
	straight flush pipe		1		screw	ST6.8*67	2
	flush pipe		1		washer	ø22*2.0	2
	eccentric pipe		1		M12 bolt		2
	rubber seal		1		decorative cap		2
	transparent air hose	transparent L:350mm	1		M12 nut		2
	blue air hose	blue L:300mm	1		big washer	ø32.5*2.5	2
	transparent air hose	transparent L:650mm	1		rubber sleeve		2
	flush pipe		1		decorative cap base		2
	rubber seal on above pipe	ø60	1		steel expansion bolts		2
	expansion nut	8*40	2		washer	ø11*1.2	2
	screw	ST4.8*45	2		toilet mat		1

Item list

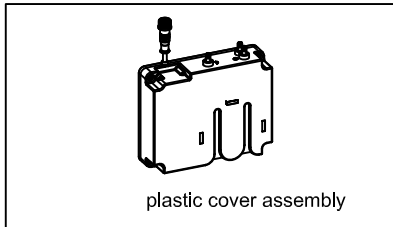
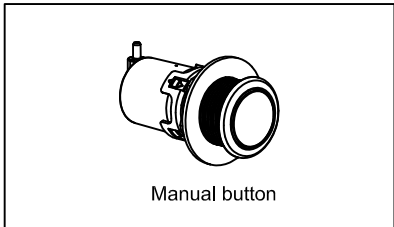
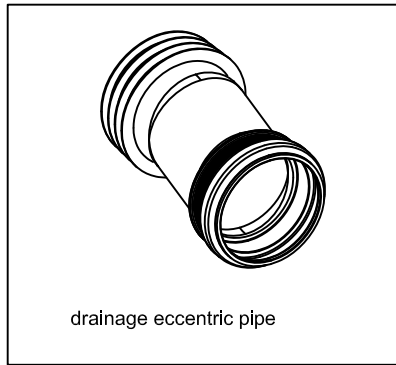
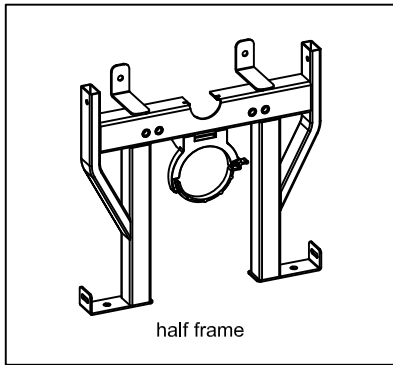
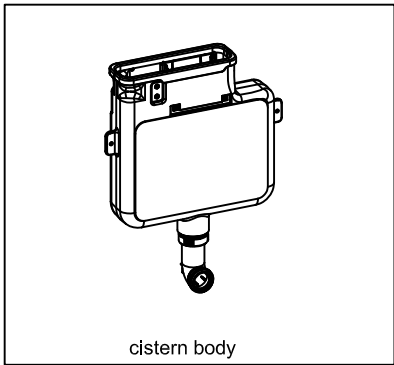
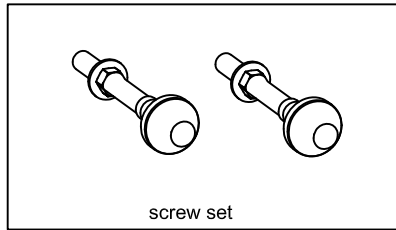
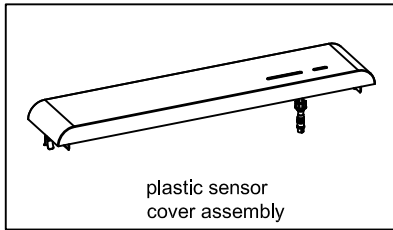
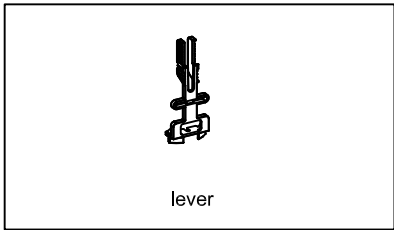
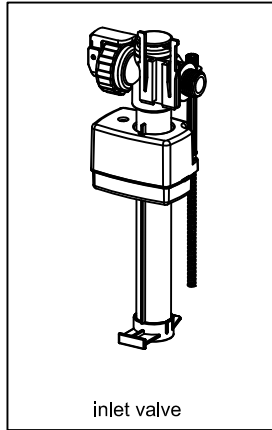
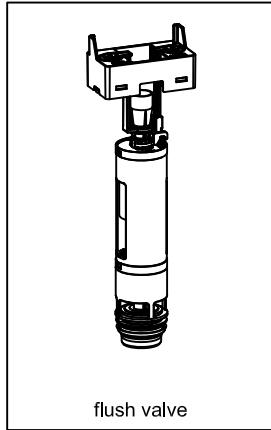
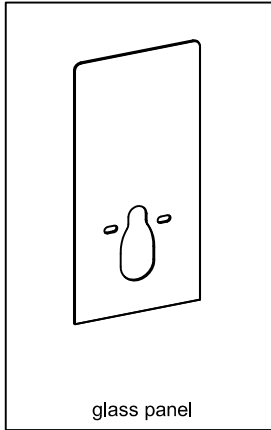
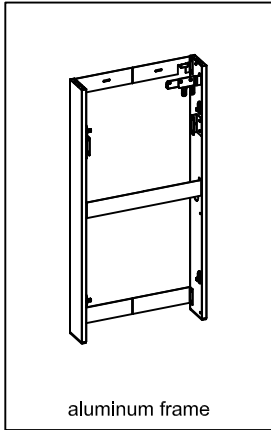

Technical Specitication

Name	Automatic Infrared cabinet cistern for wall-hung WC	
Model	SP-S18	
Technical Specification	rated voltage	220V AC, 50HZ
	ambient temperature	3~40°C
	water supply pressure	0. 07~0. 75MPa
	water supply temperature	4~35°C
	waterproof rating	IPX4
	dimension	1003. 5mm X 483mm X 108mm

Technical drawing, inlet system & drainage system suggestion

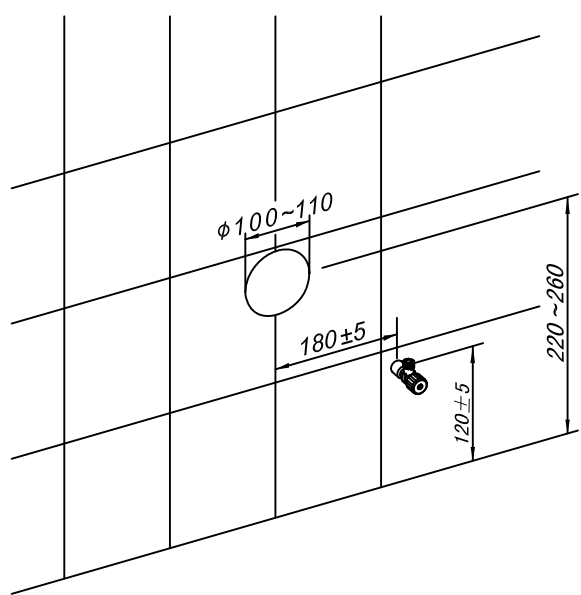
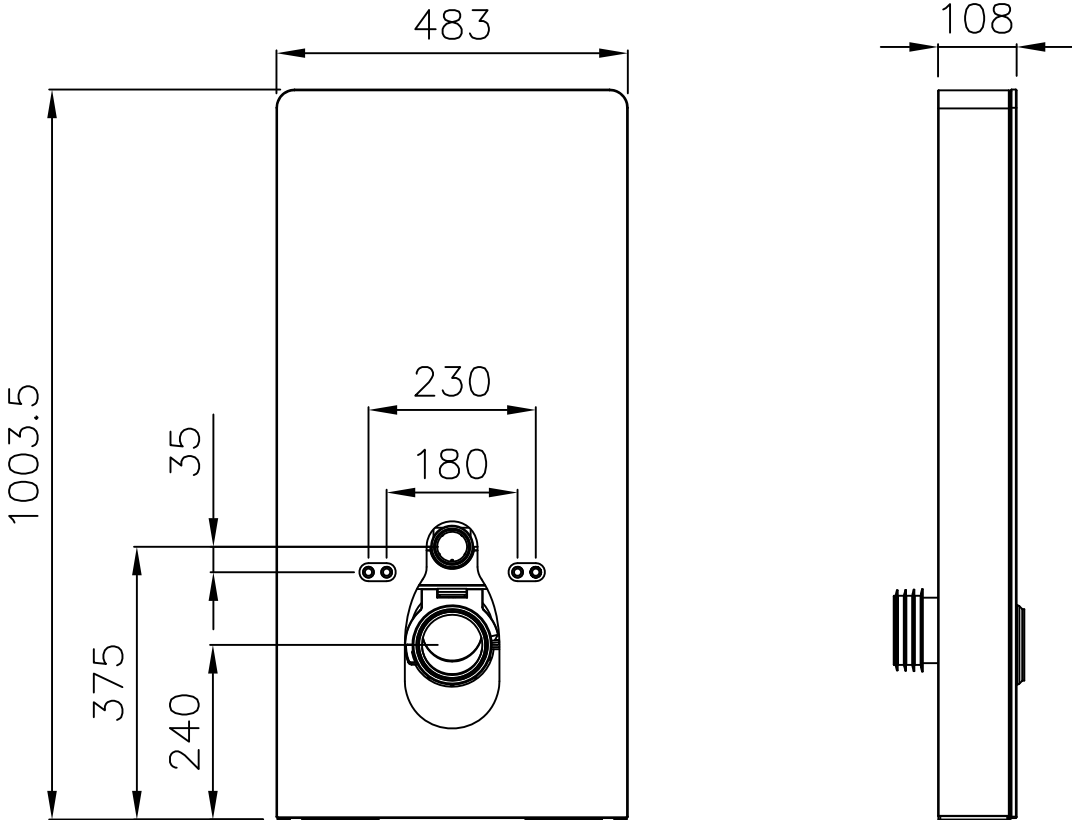

1

Cistern installation

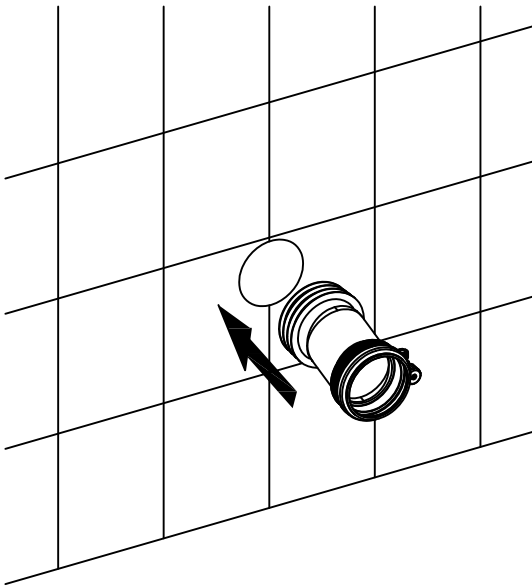

Insert the drainage pipe into the drainage hole on the wall.

2

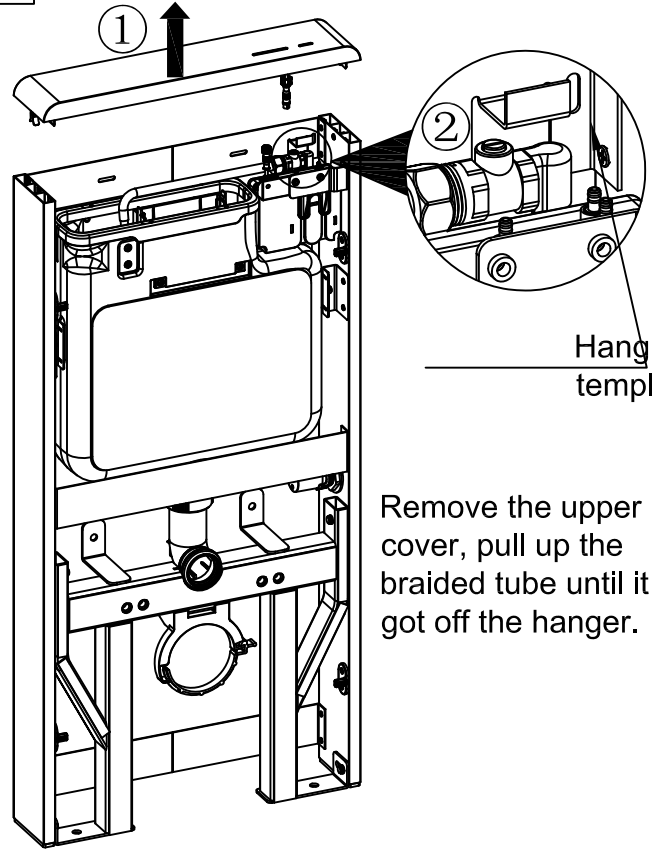

Remove the upper cover, pull up the braided tube until it got off the hanger.

3

Lean the whole cistern to the wall and align the flush pipe position with the buckle.

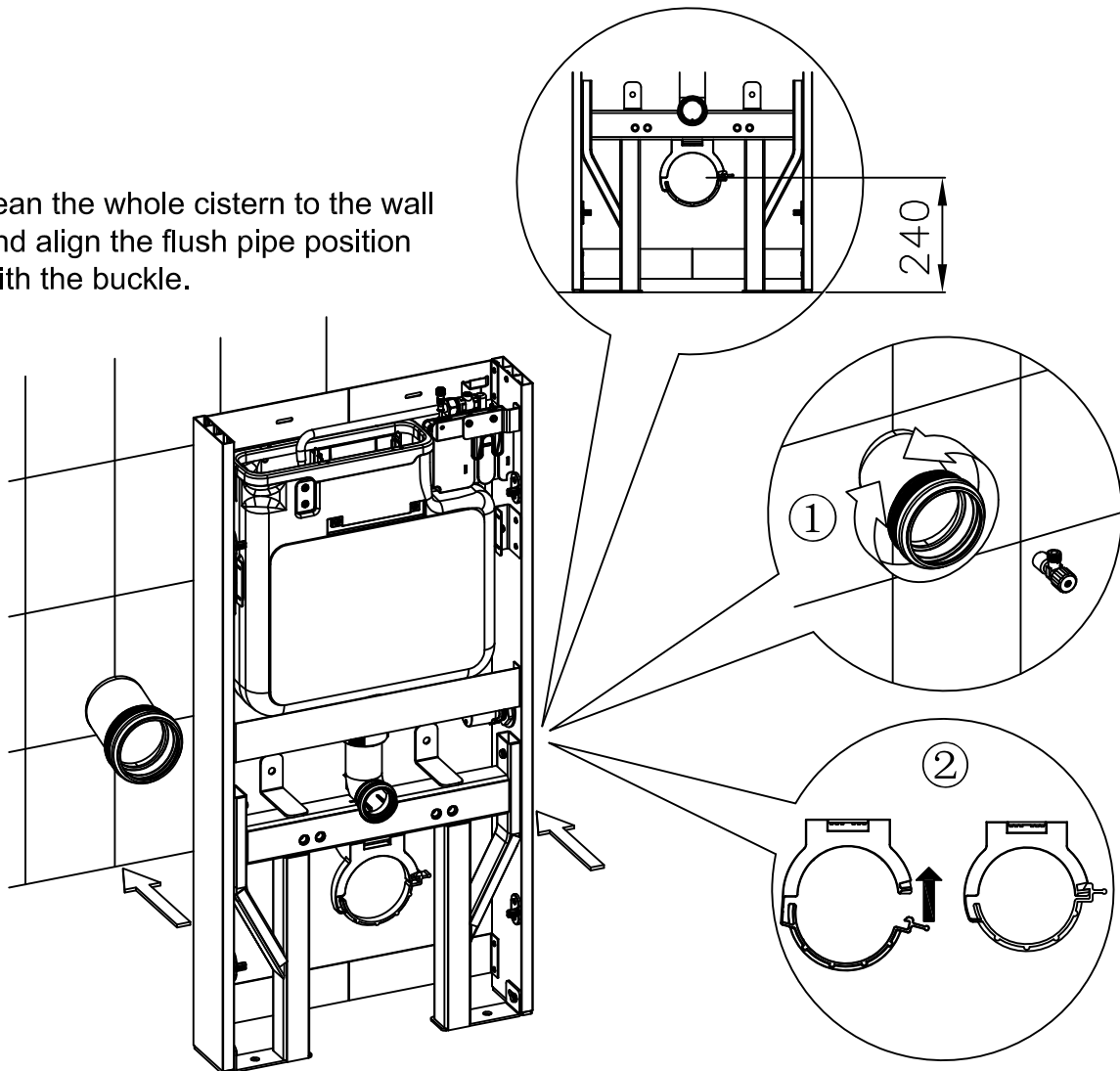

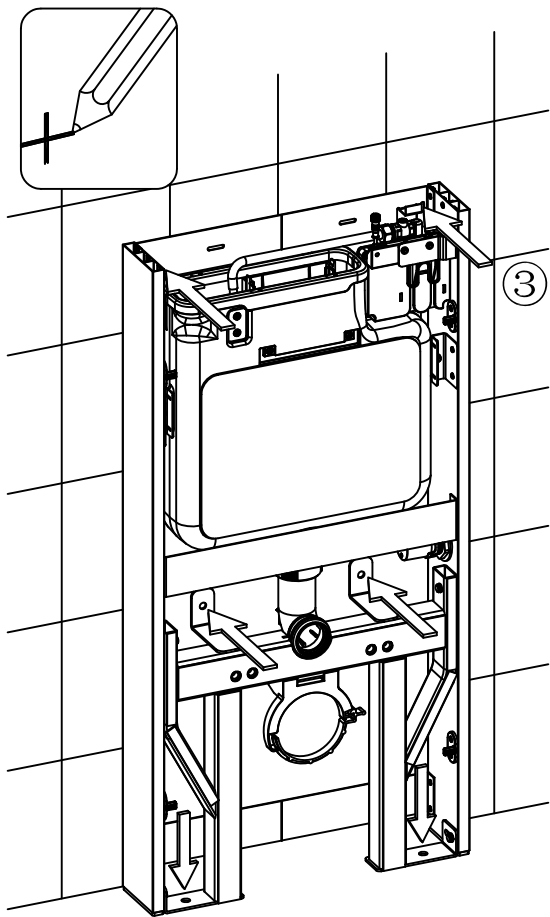

As indicated by the arrow, mark 4 spots on the wall and 2 spots on the ground accordingly.

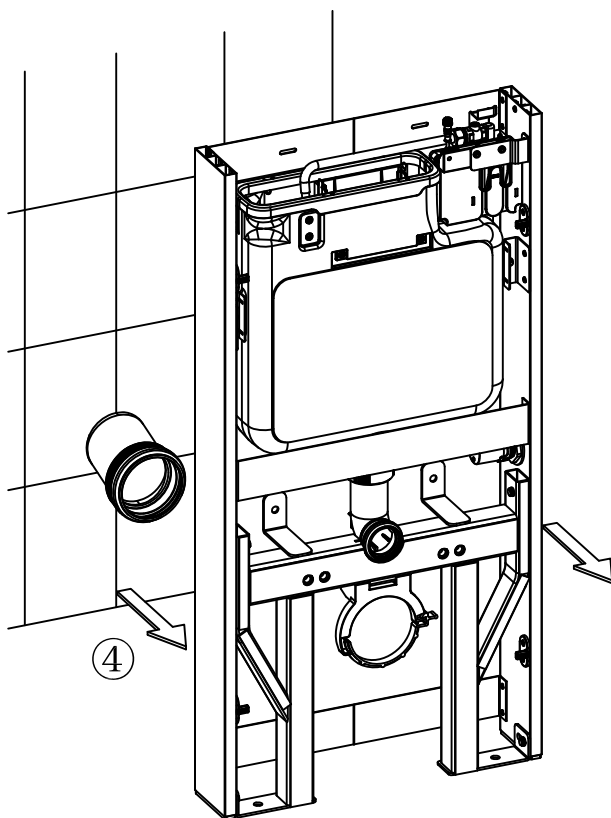

Then move off cistern first.

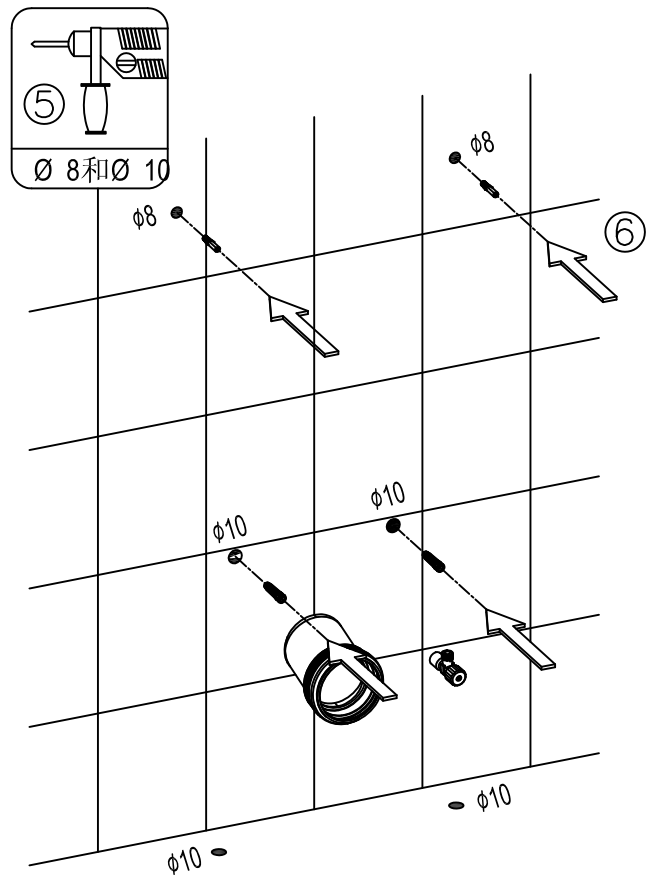

Drill the holes to the marked spots (Note the depth of the drill must be larger than the length of expansion nut, the diameter shown as the picture) and press the corresponding expansion nut into the hole.

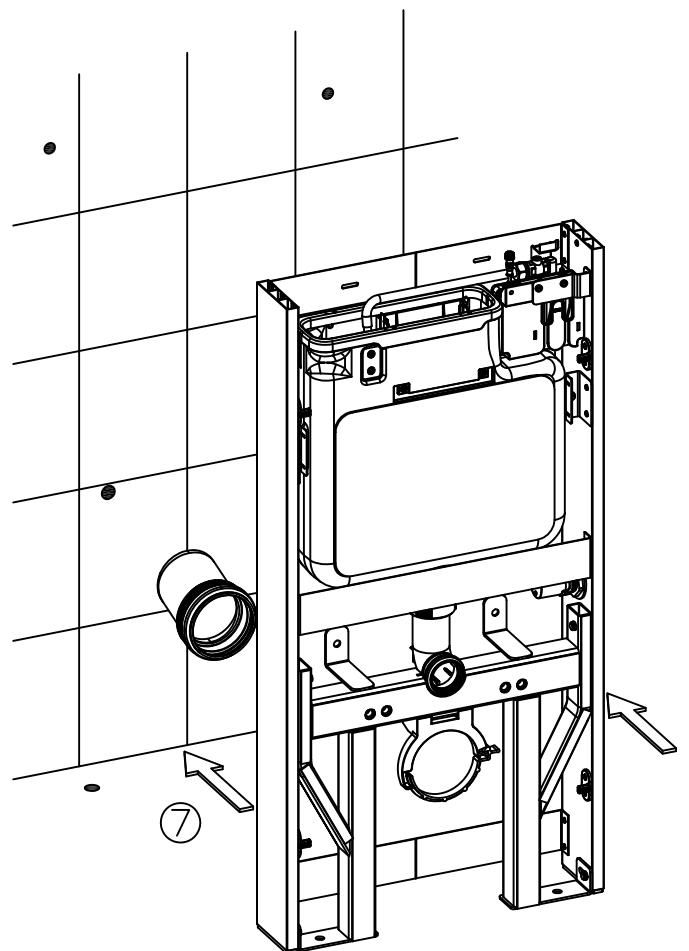

Lean the whole frame into the right position of the wall.

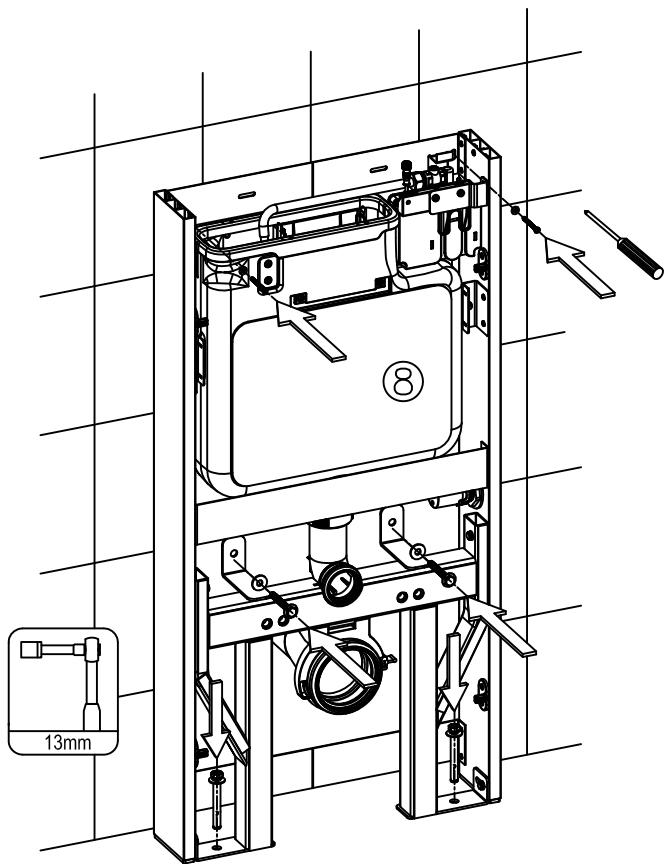

Lock the corresponding size of the screws into the expansion nut in the wall and steel expansion bolt on the floor.

4

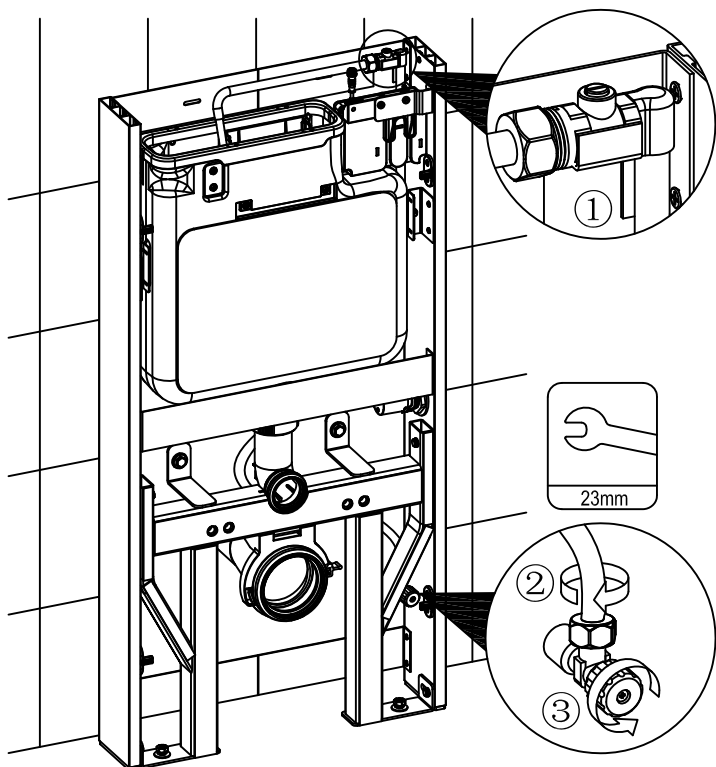

Buckle the braided tube onto the hanger again, and connect the tube to the angle valve on the wall.

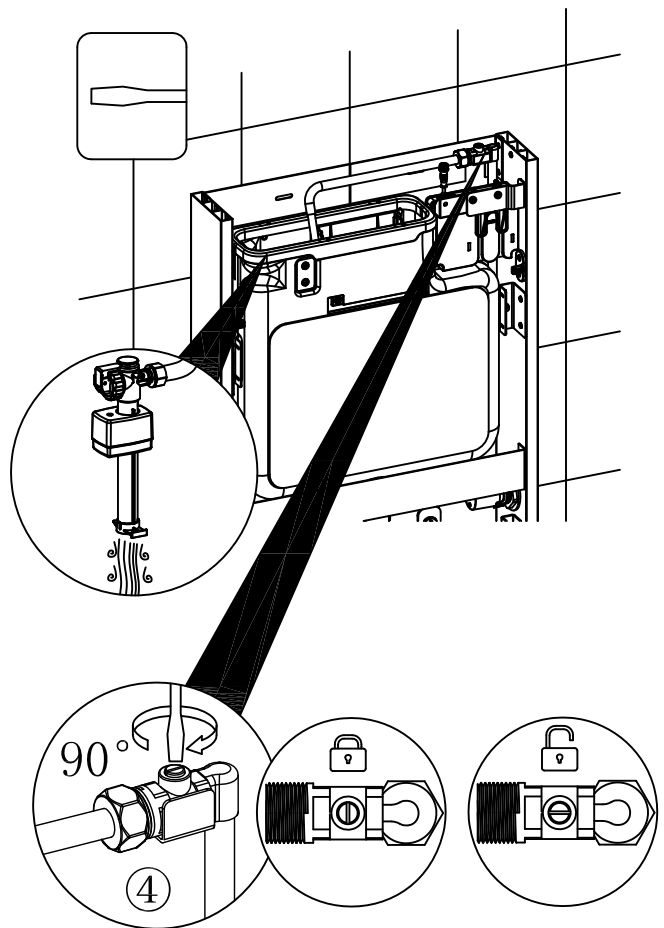

Open the stop valve on the hose to see whether it is in good condition.

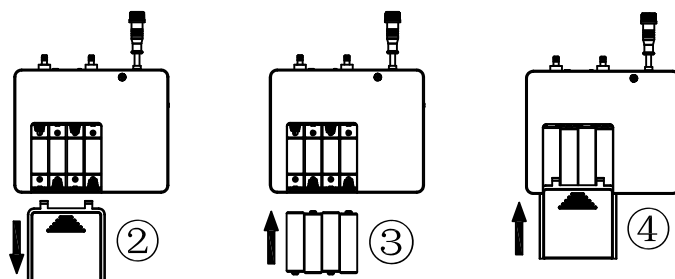
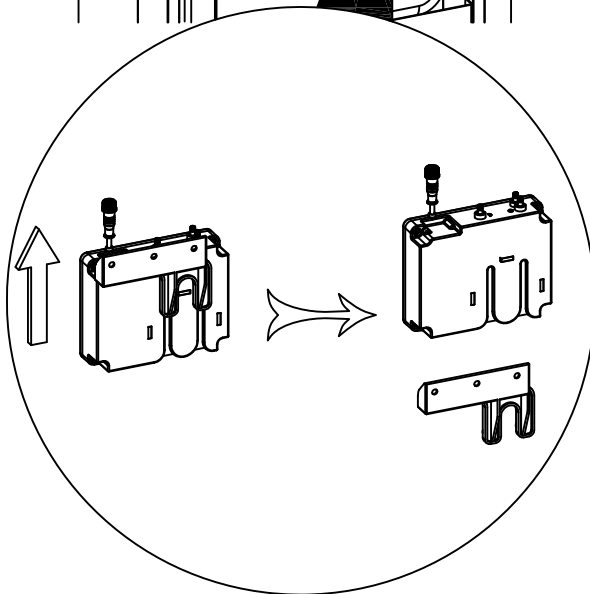
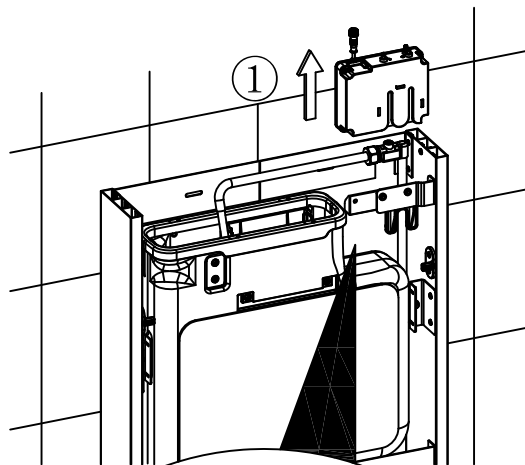

Mark: All batteries should be AAA batteries , and please do not mix old and new batteries when using.

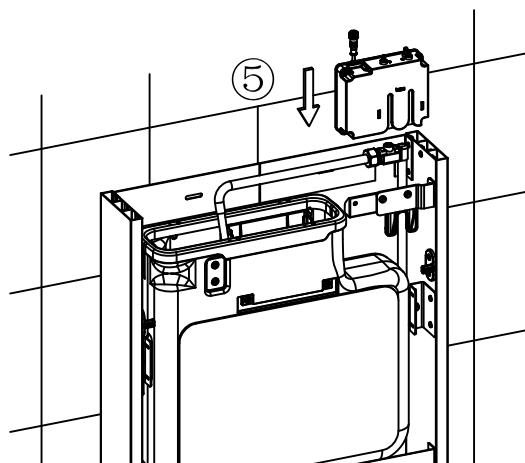

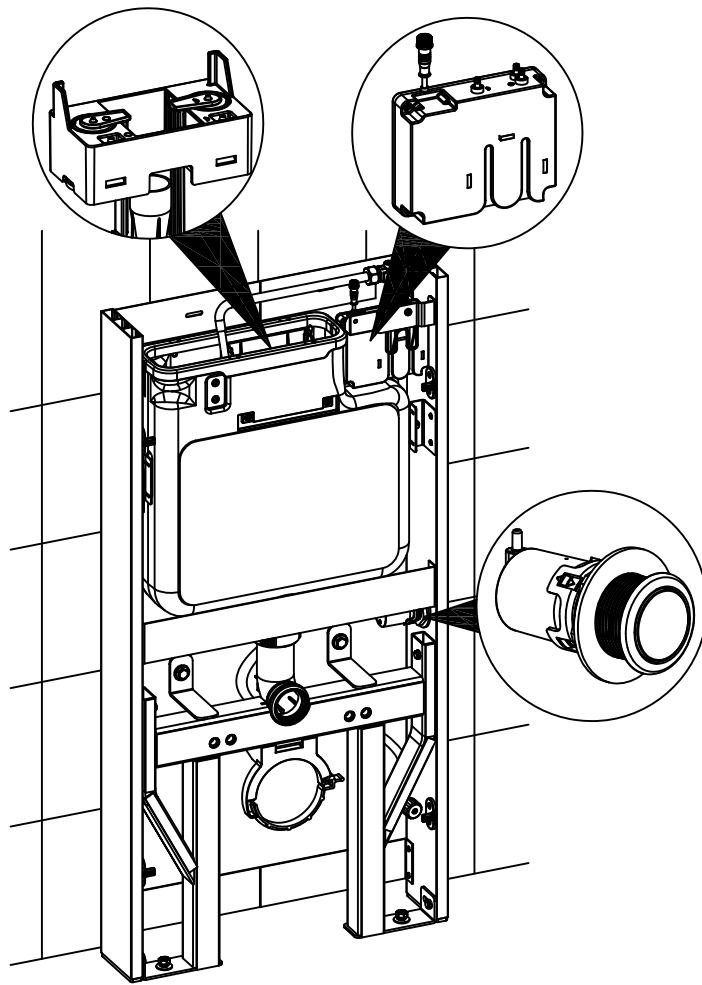

⑥

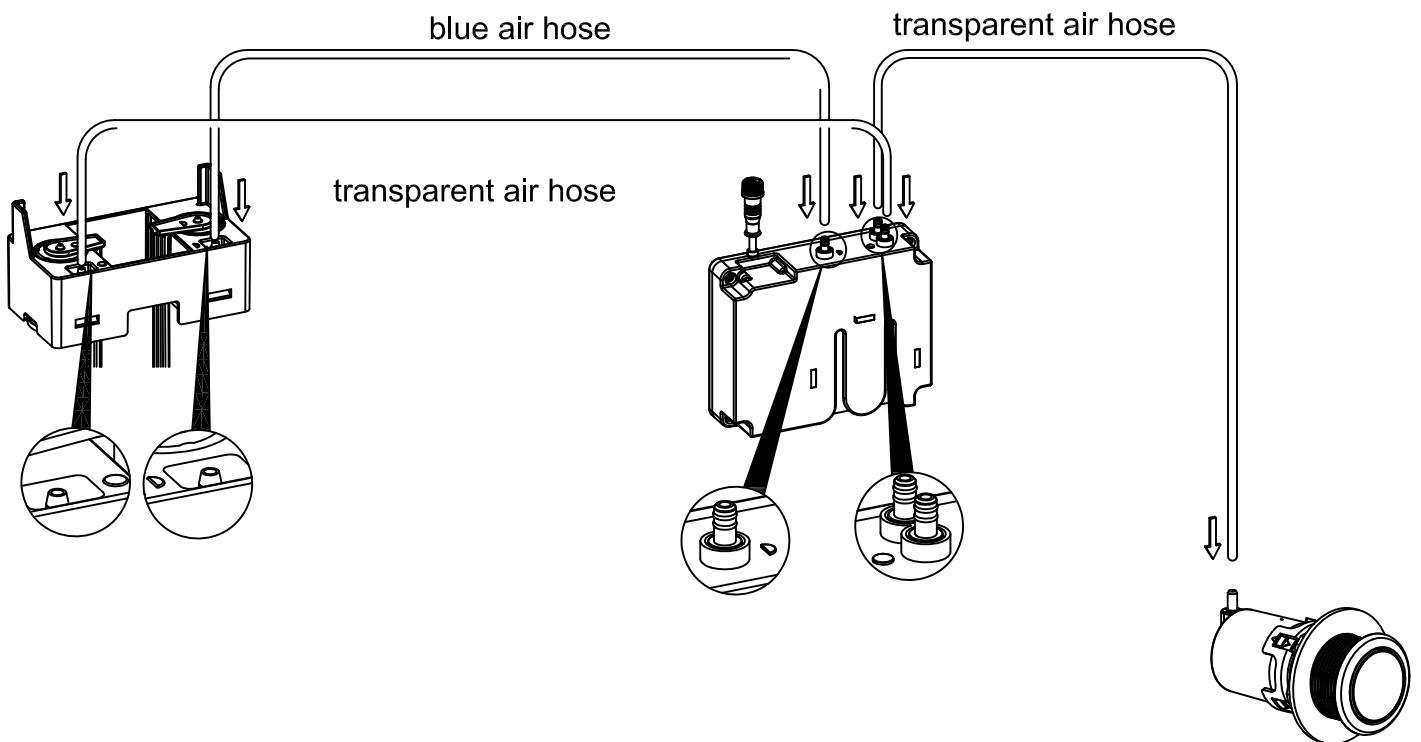

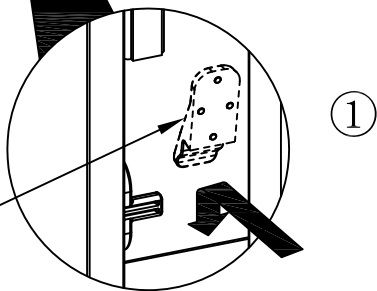
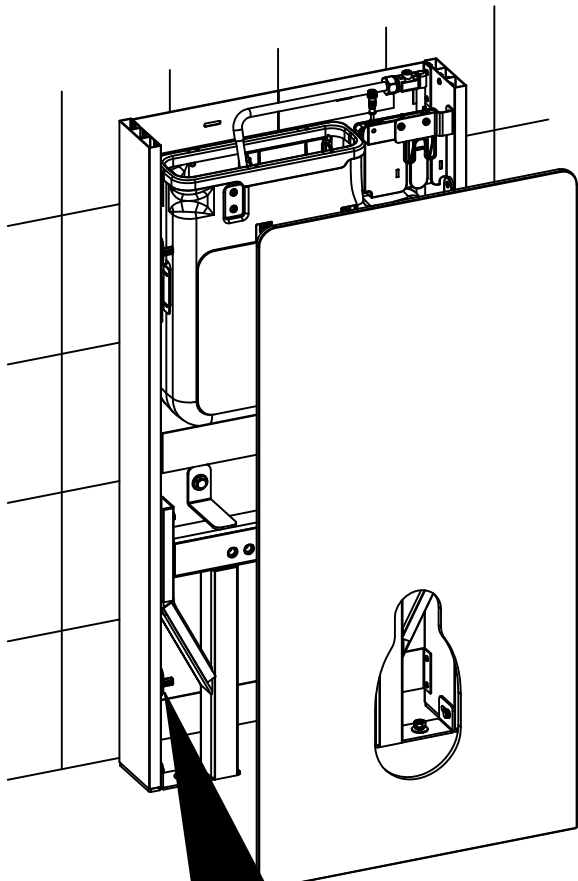

Glass support buckle
stuck on the
glass(4pcs).

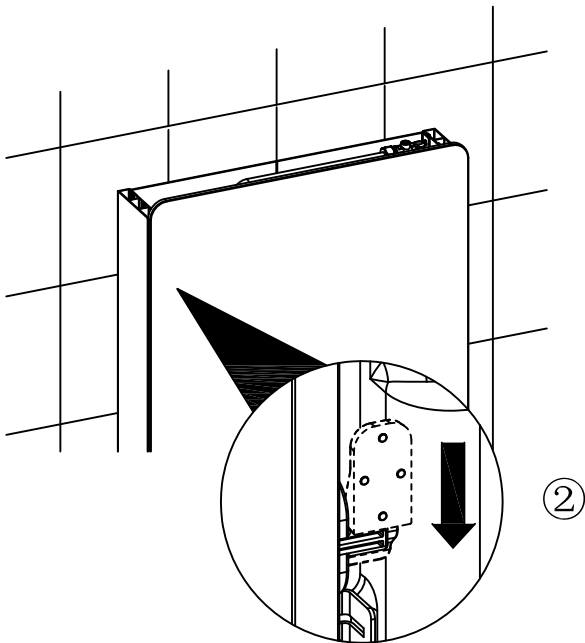

Install the glass onto the aluminum
frame and push downward the glass
support buckle until the buckles lock
with pendant the aluminum frame.

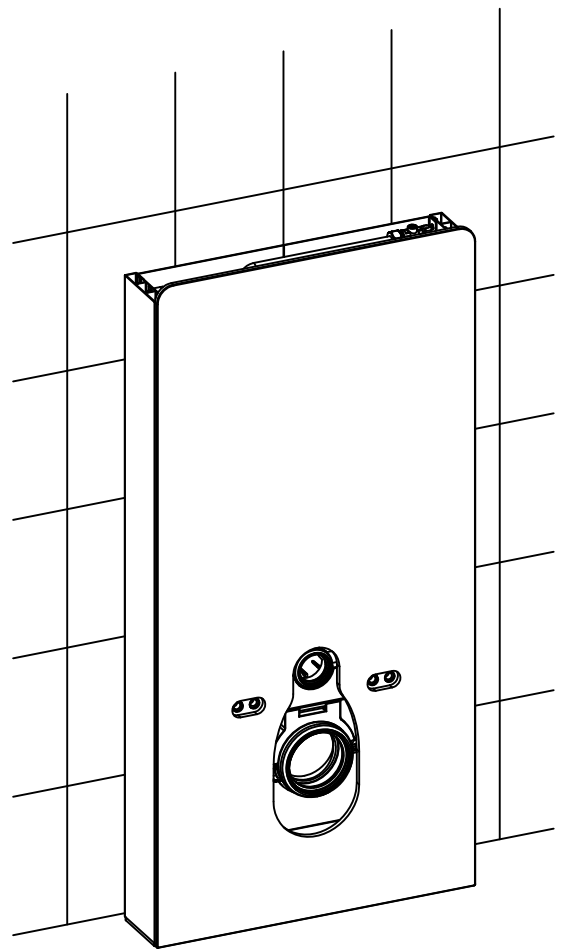

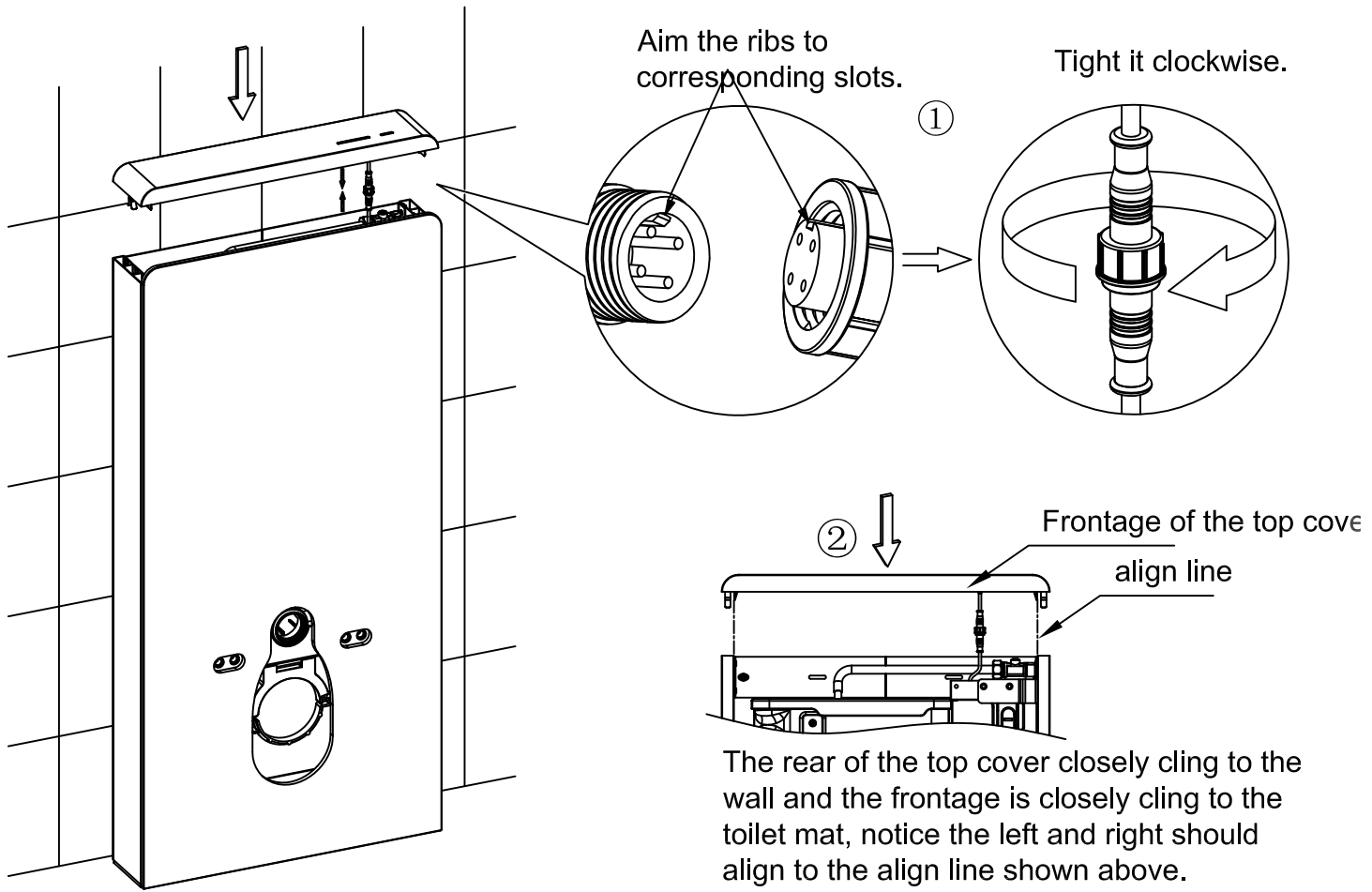

Assemble the cover back to the cistern frame.

The rear of the top cover closely cling to the wall and the frontage is closely cling to the toilet mat, notice the left and right should align to the align line shown above.

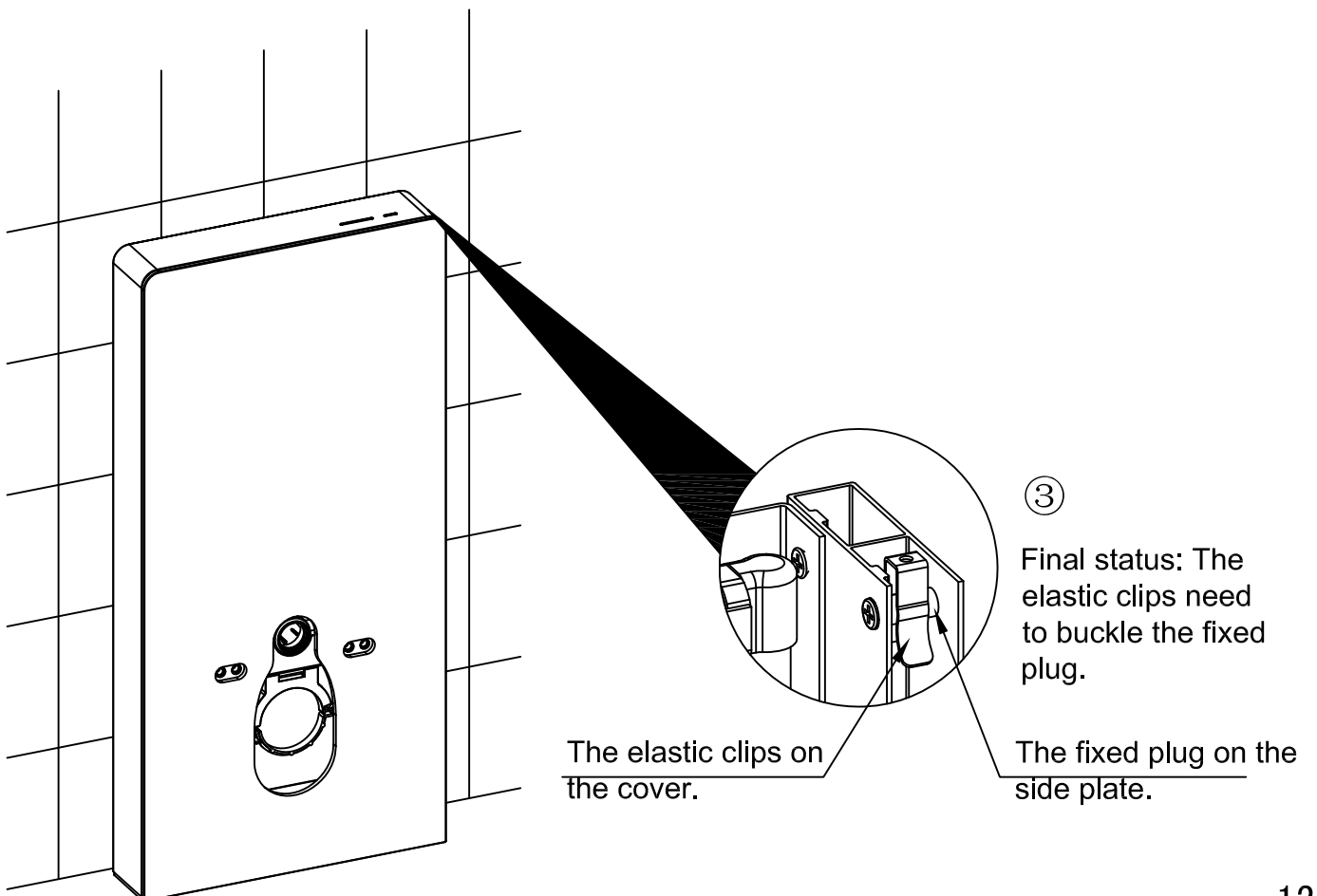

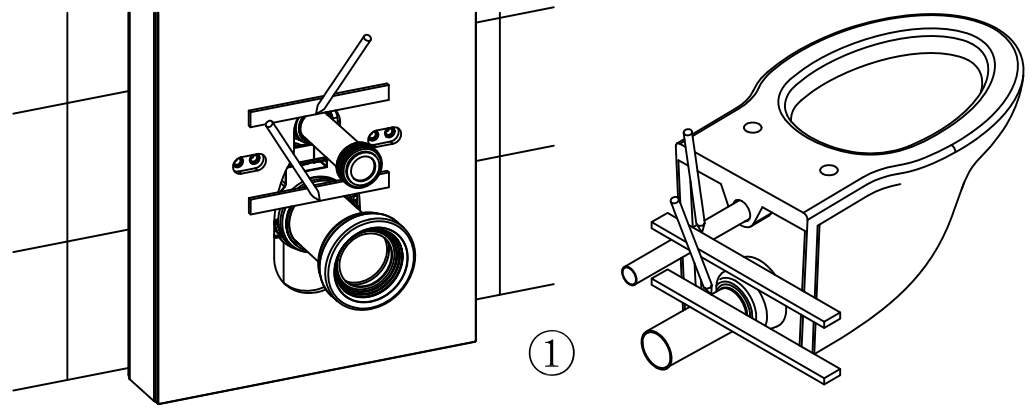
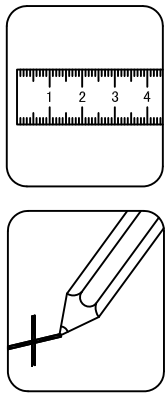

Draw line on the straight flush pipe and drain pipe.

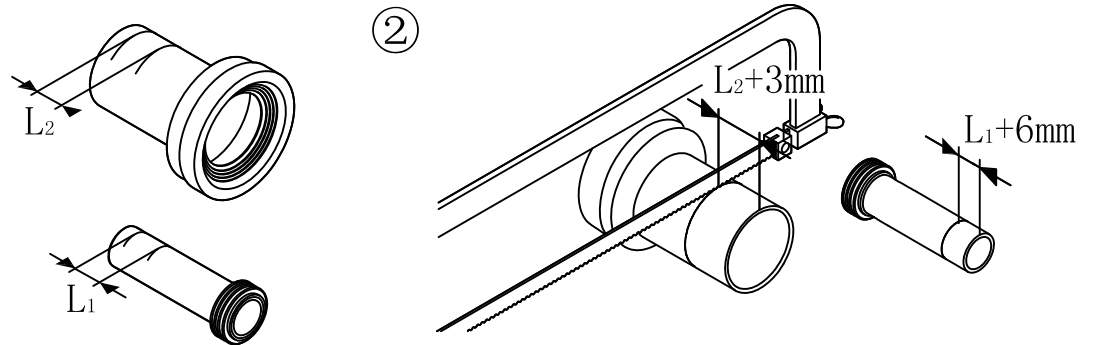
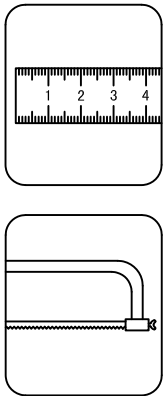

Cut the flush pipe and drainage pipe.

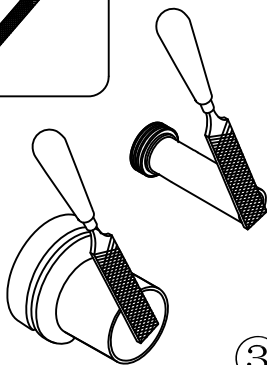
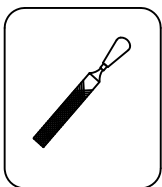

Apply chamfer on the mouth of the flush pipe and drain pipe.

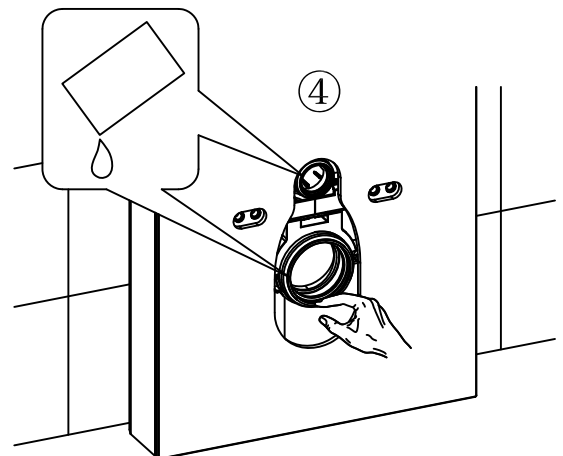
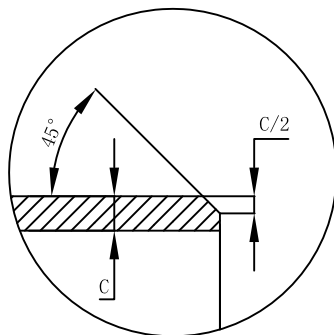

Apply silicone oil.

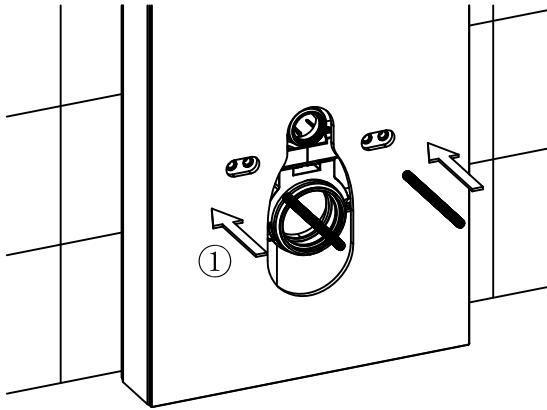
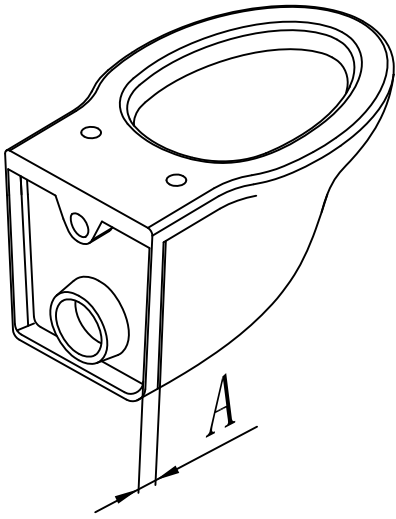

Screw the bolts into the cistern frame

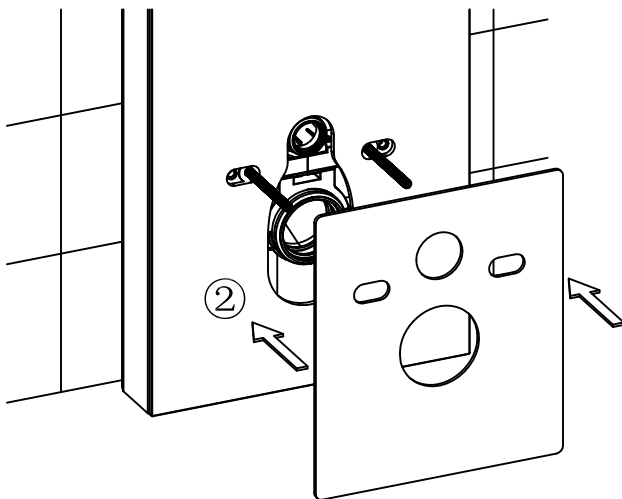
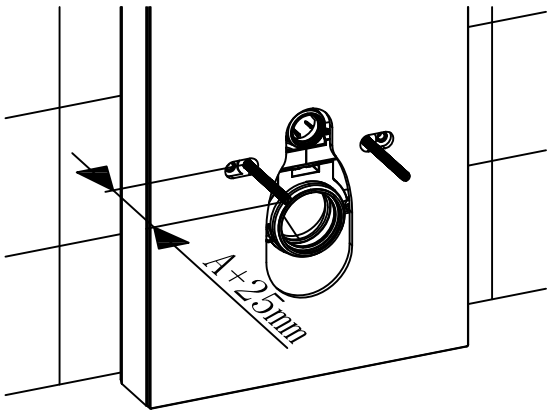

Install toilet mat.

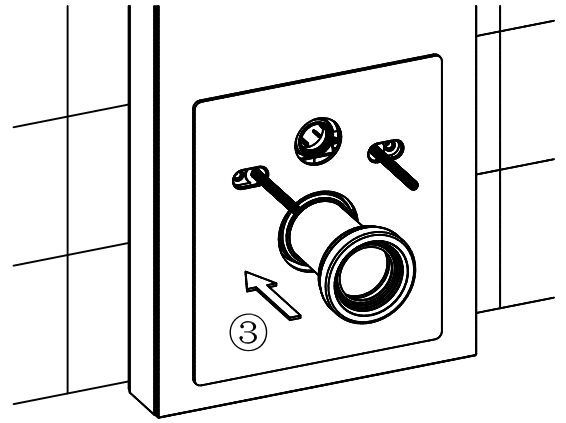

Install the flush pipe onto the cistern,

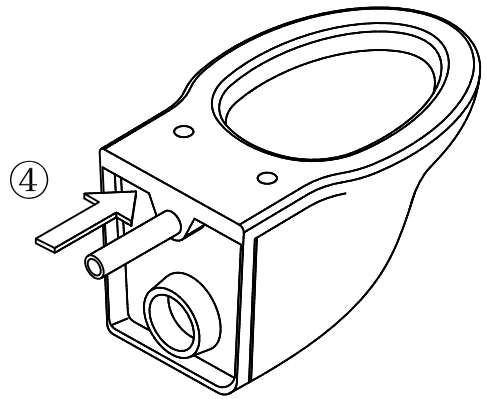

Install the flush pipe onto the toilet.

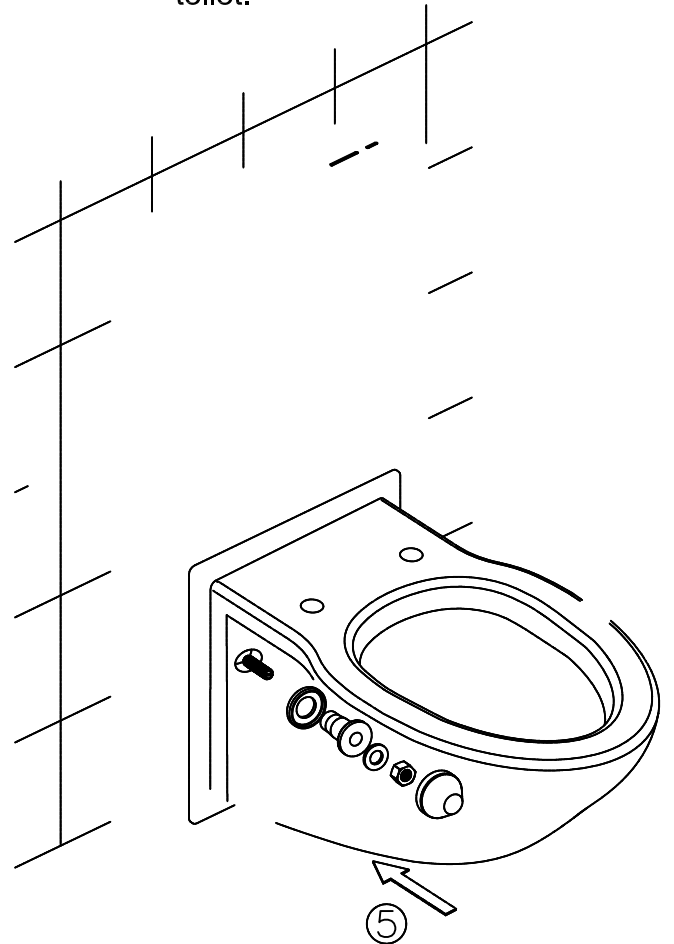

Install toilet.

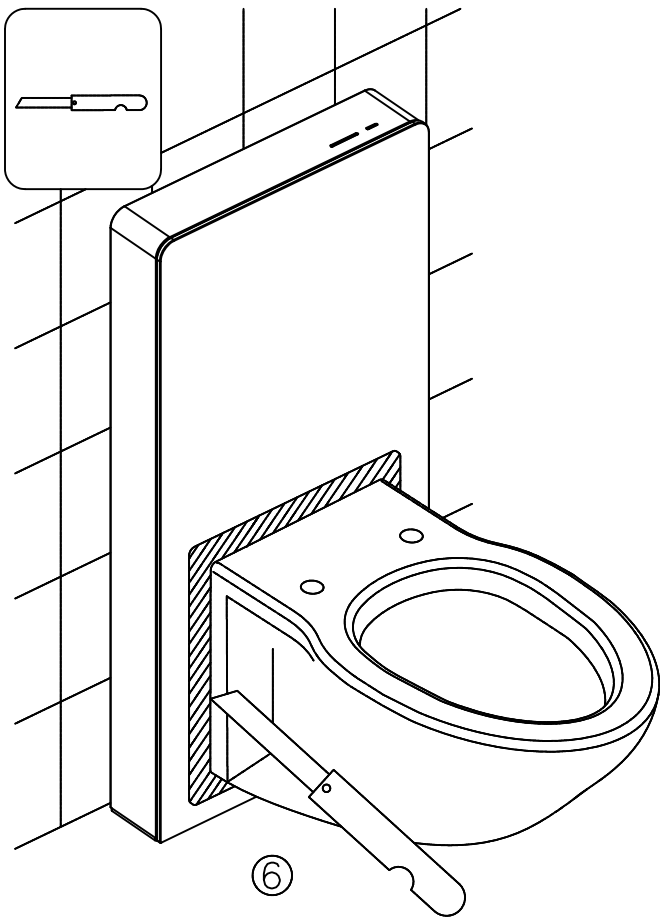

Cut off extra part of the toilet mat.

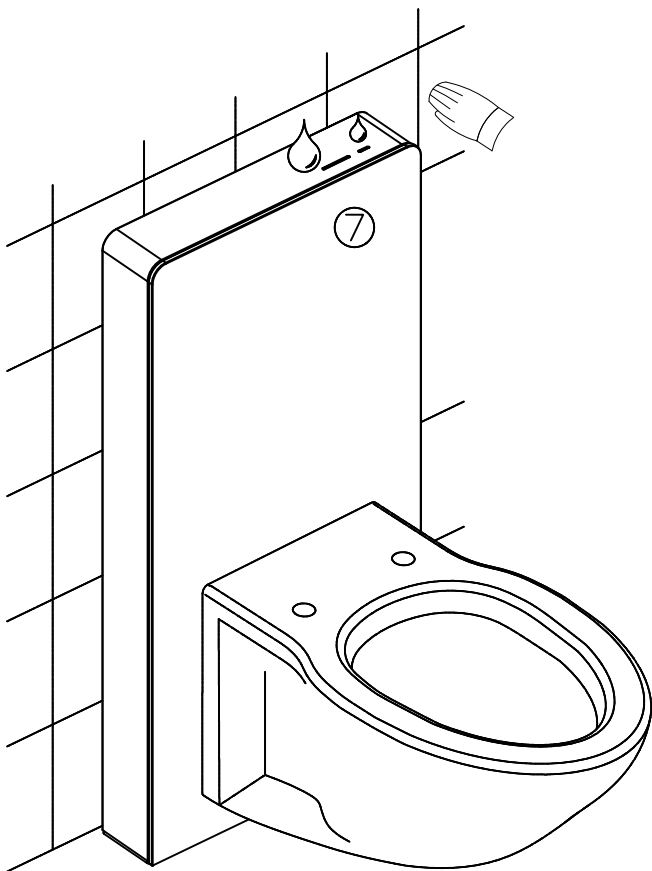

Sensor area: wave your hand within around 50 mm from the top cover to test the function of half & full flush.

Maintenance & daily care

1.1 Inlet valve removal

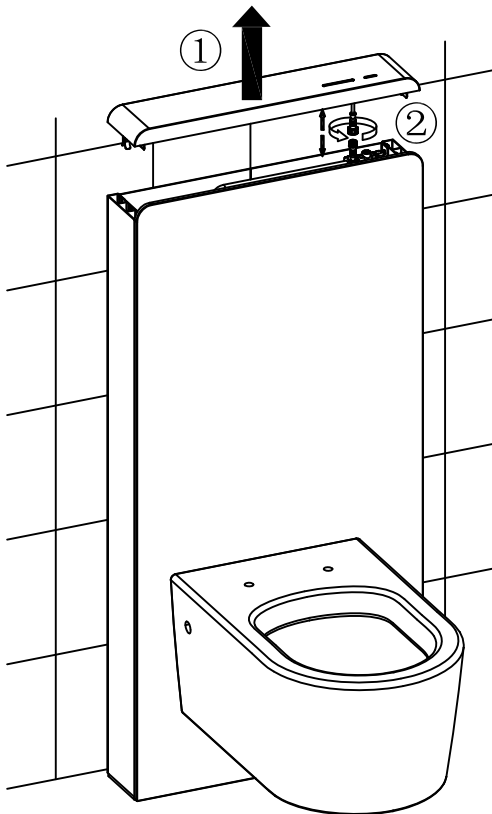

Remove the top cover and unplug the mating parts.

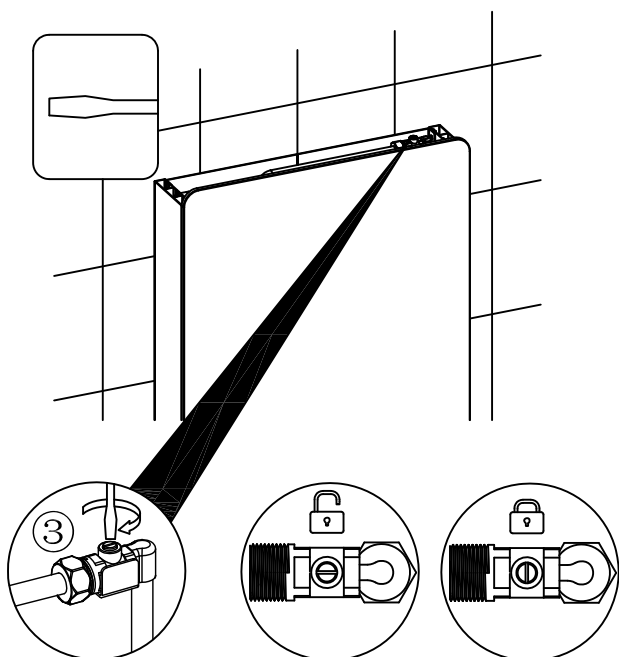

Turn off the stop valve on the flexible hose.

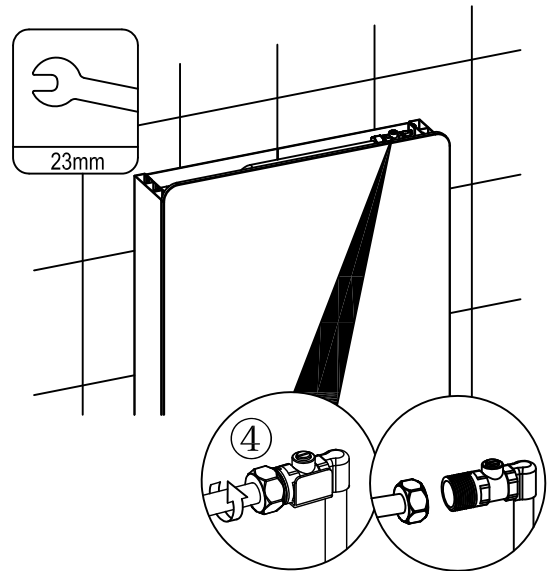

Disconnect hose and the valve.

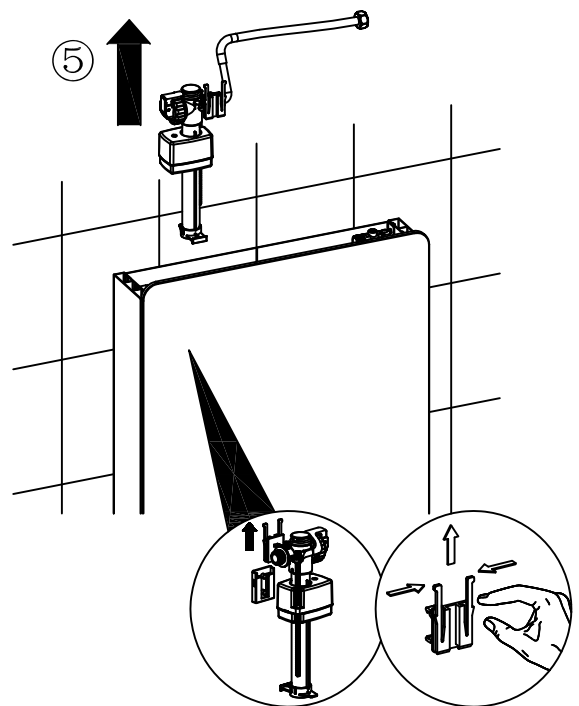

Take off the inlet valve upwards.

1.2 Inlet valve adjustment & clean

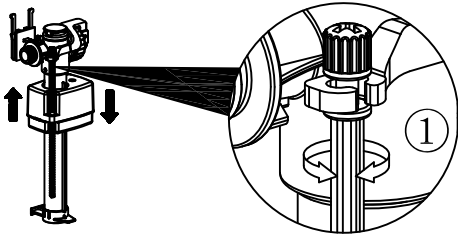

Adjust the float upwards to increase the inlet volume; or downwards to reduce the volume.

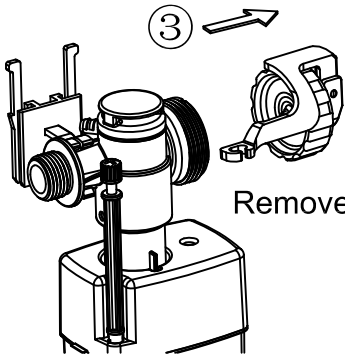
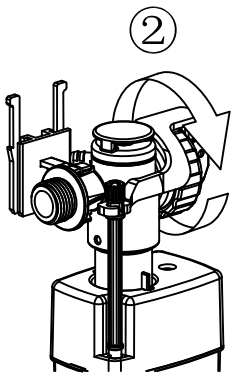

Remove the water-stopping part.

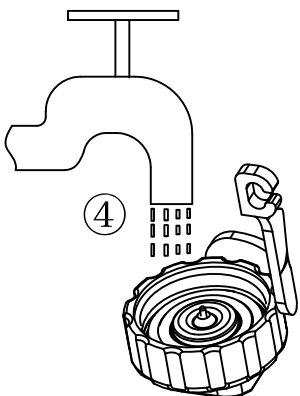

Wash this removed part.

1.3 Inlet valve installation

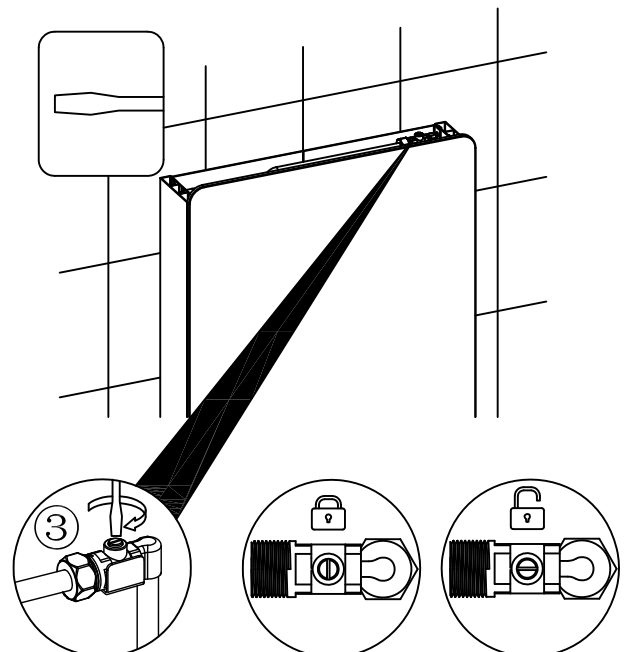
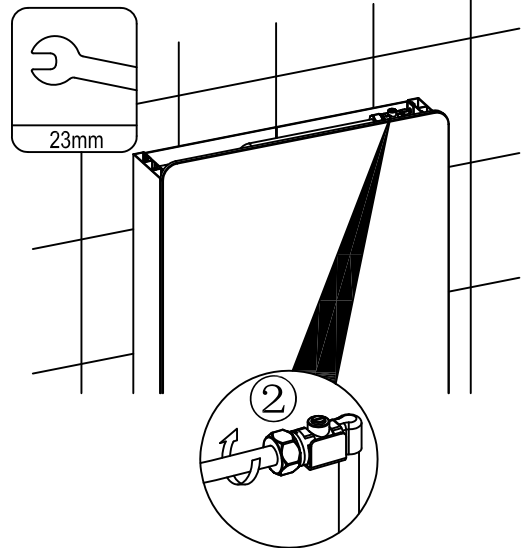
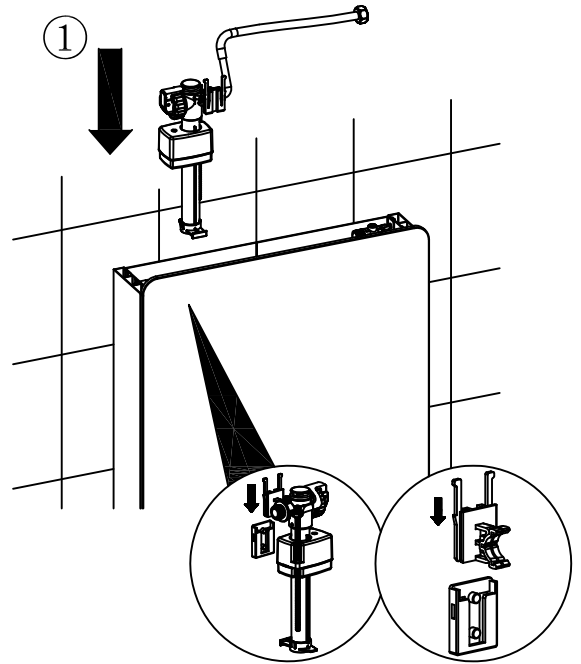

2.1 Flush valve removal

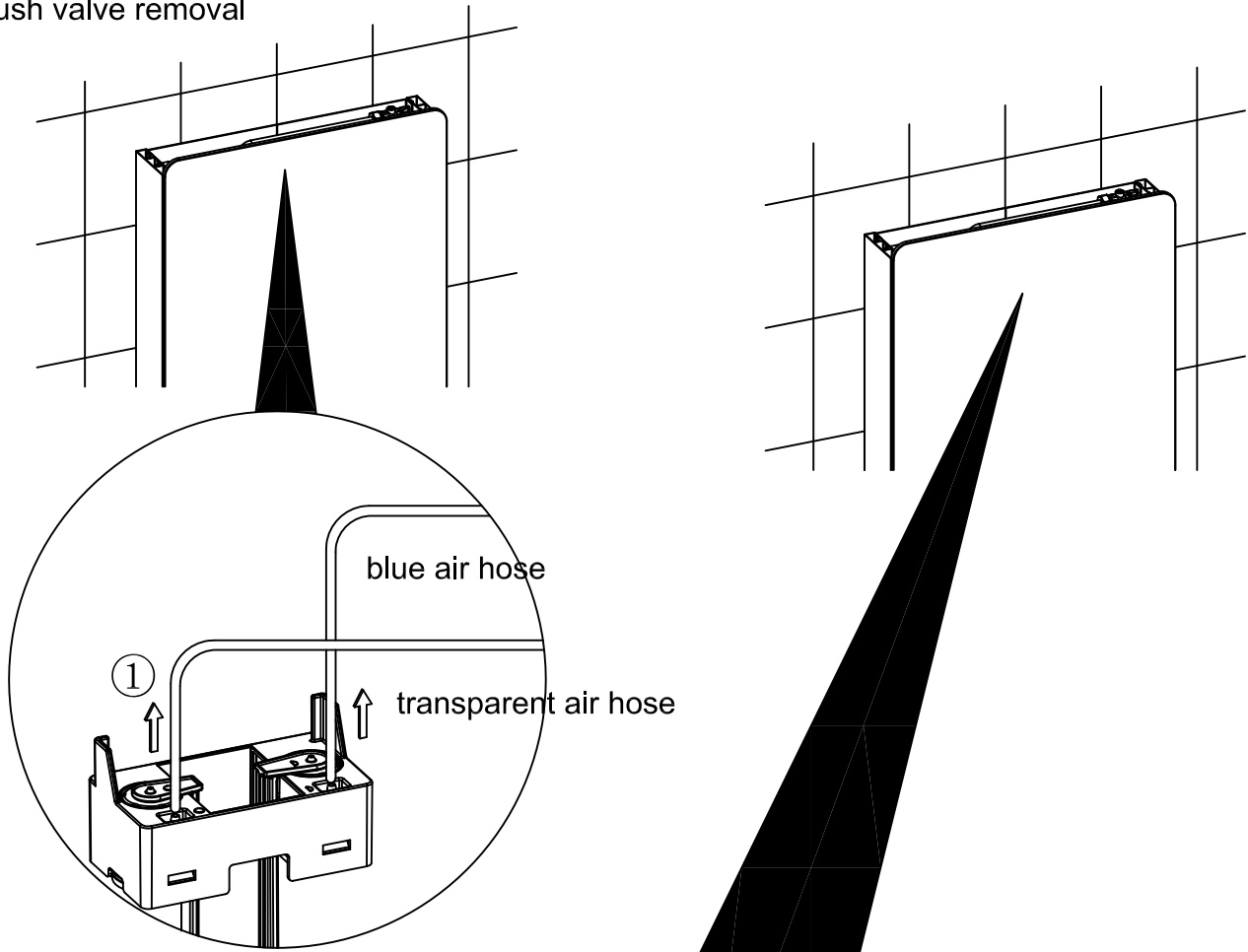

Disconnect the air hoses from the air hose holes.

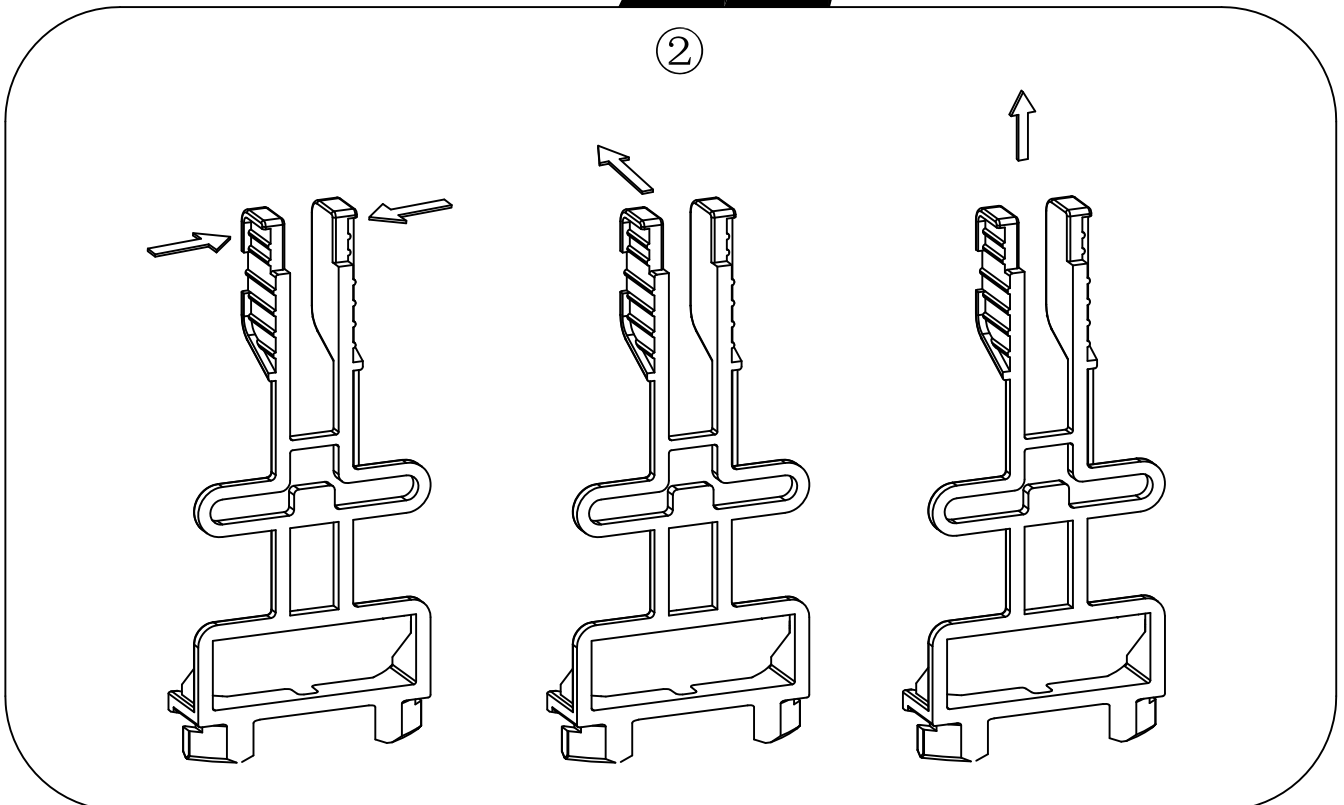

Remove the lever.

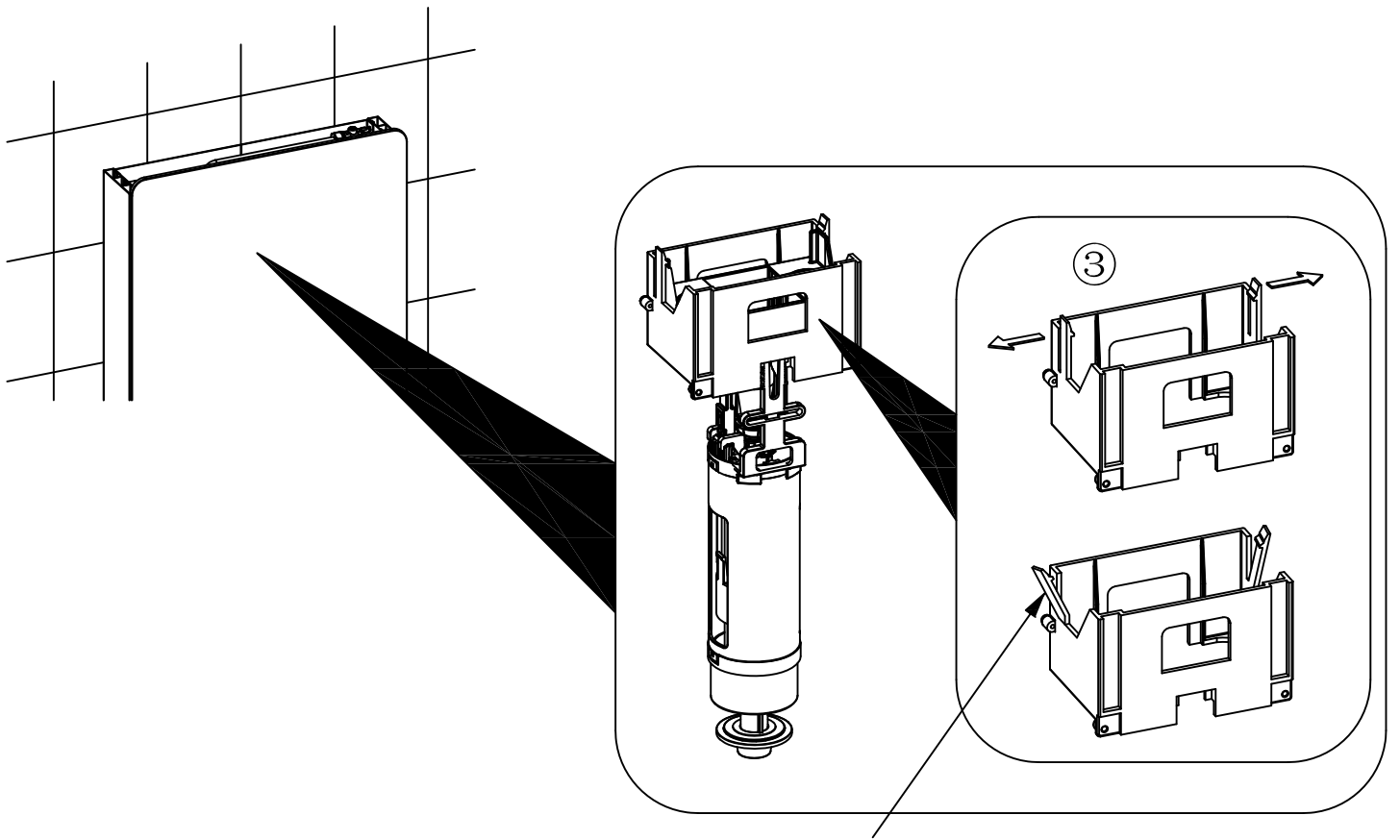

Buckles on the cistern hanger.

Lift upwards the flush valve after opening the buckles on the cistern hanger.

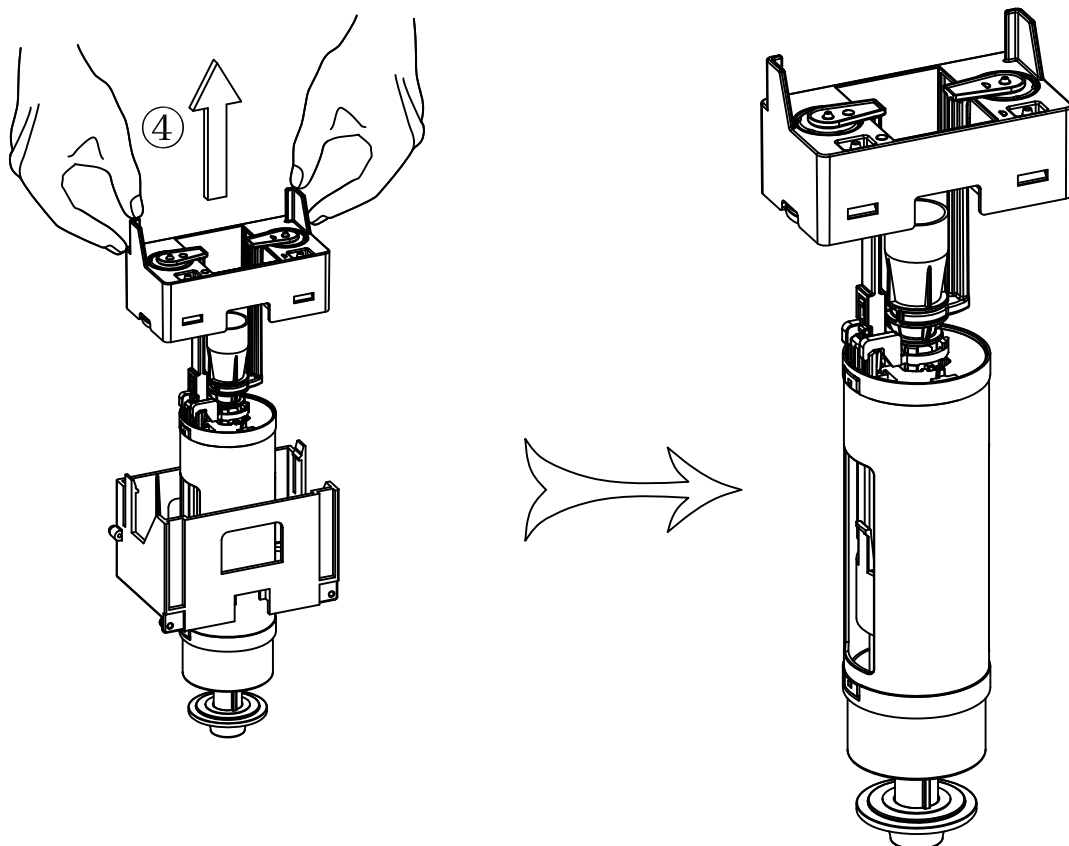

2.2 Flush valve adjustment & clean

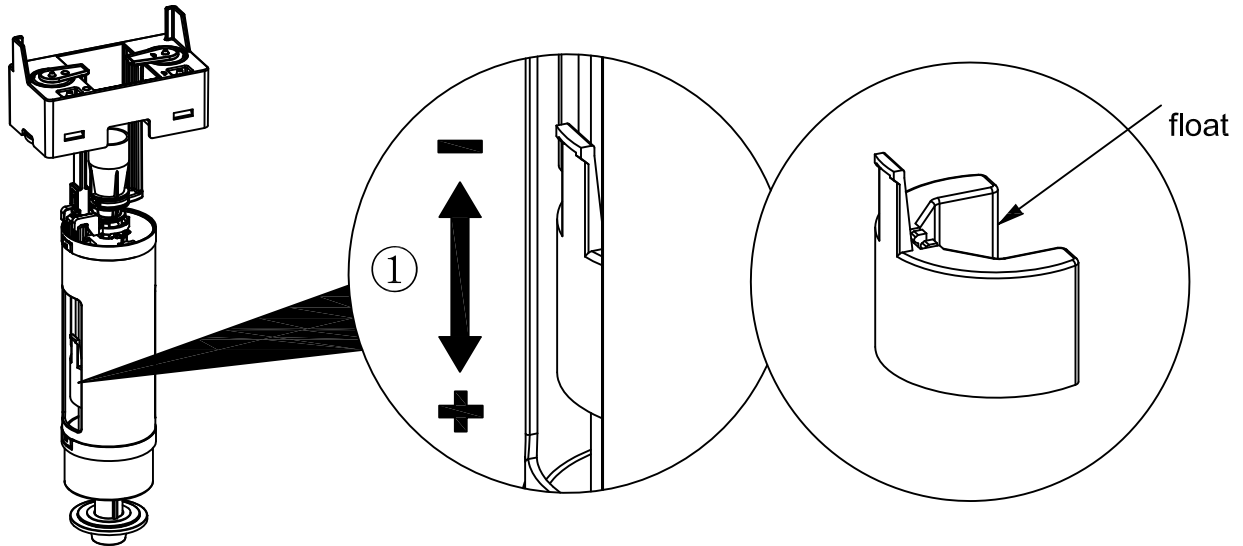

Adjust the float upwards to reduce the flush volume;
or downwards to increase the volume.

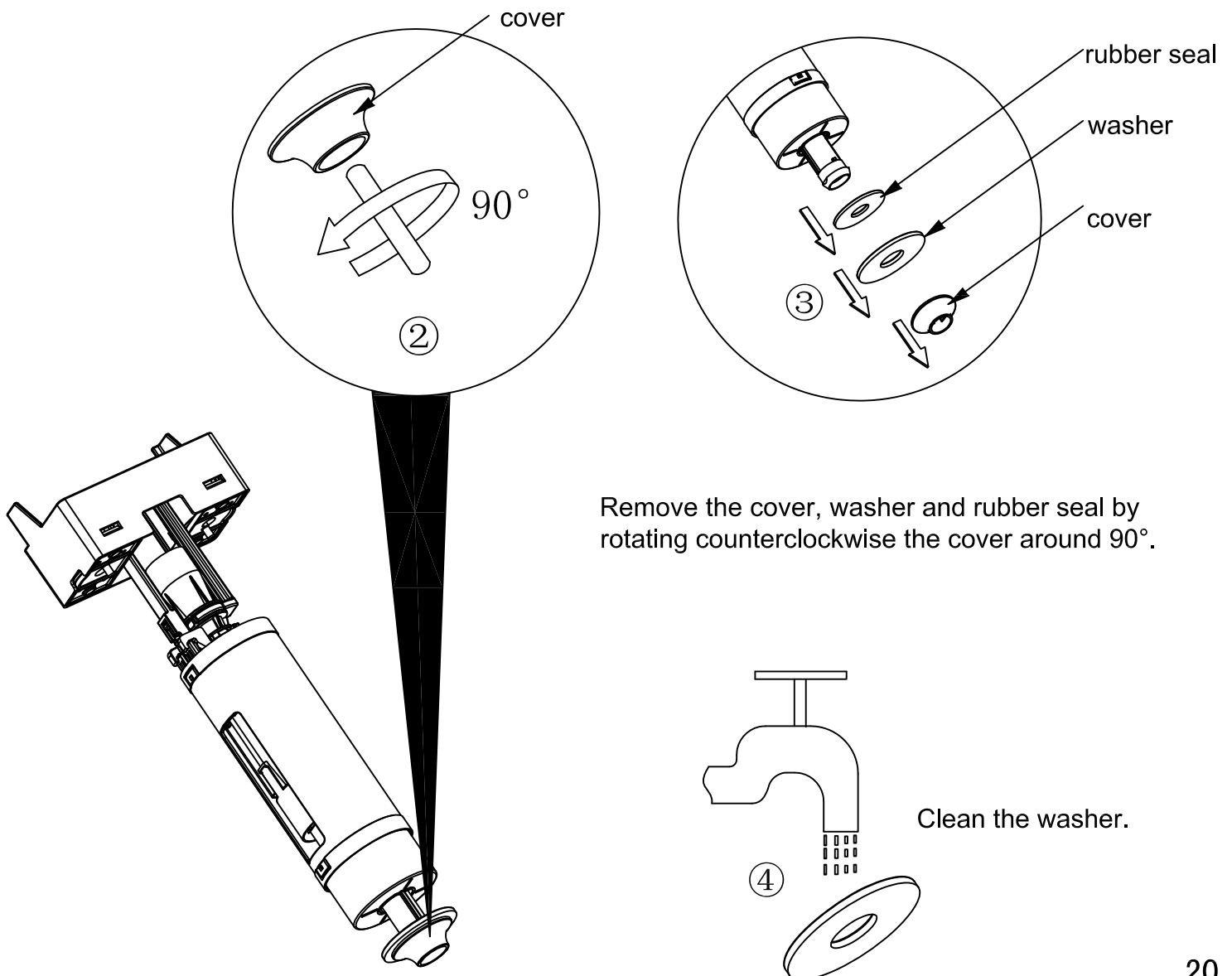

2.3 Flush valve installation.

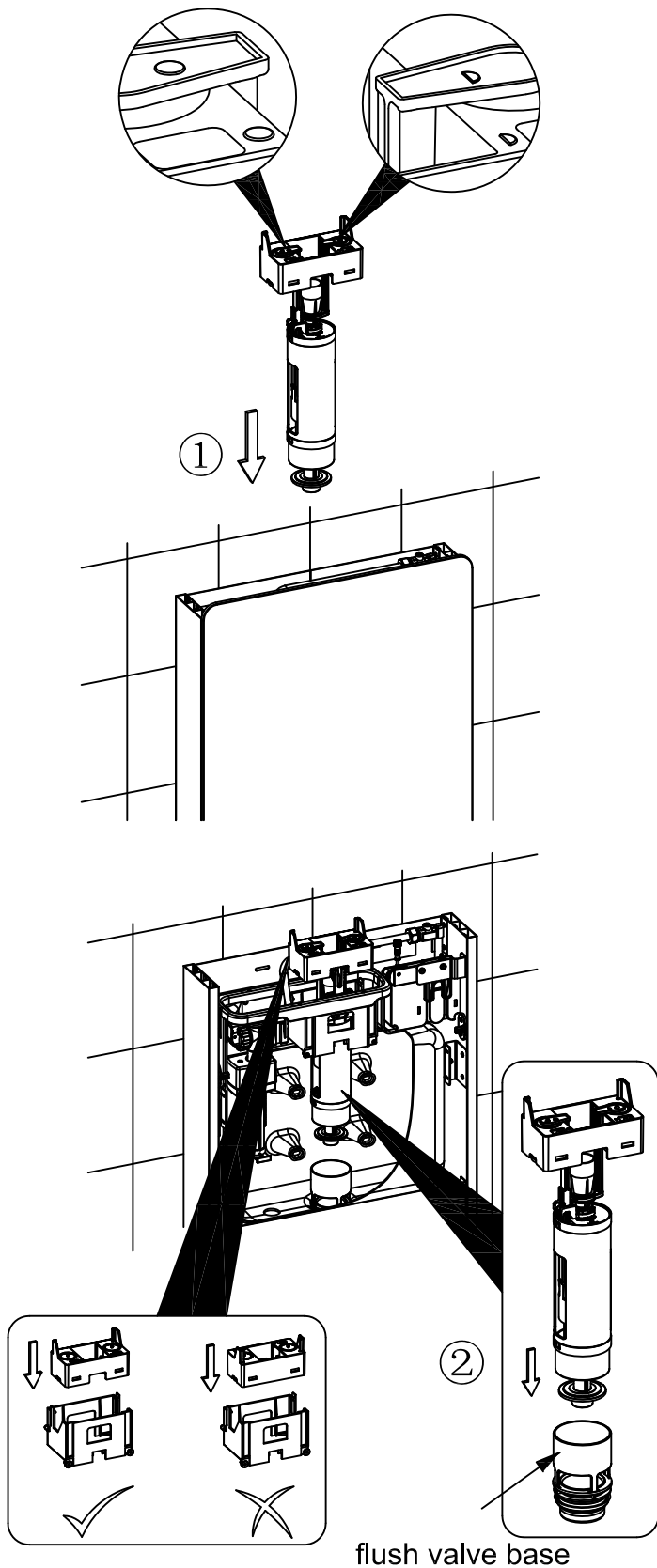

Install the flush valve downwards into the cistern body (Mark: make sure the flush valve bottom is aligned with flush valve base. And please make sure flush valve is installed in the shown direction during installation.

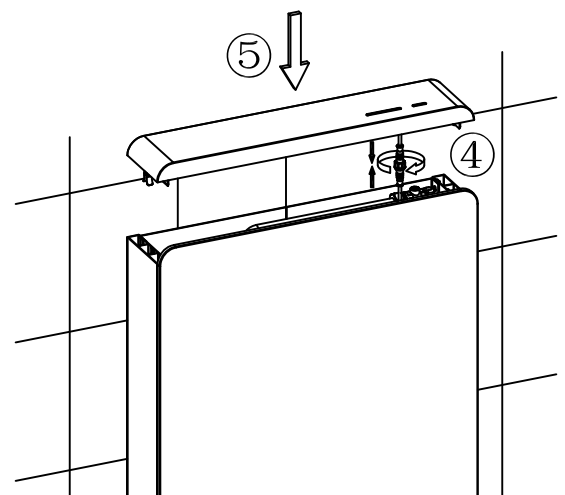
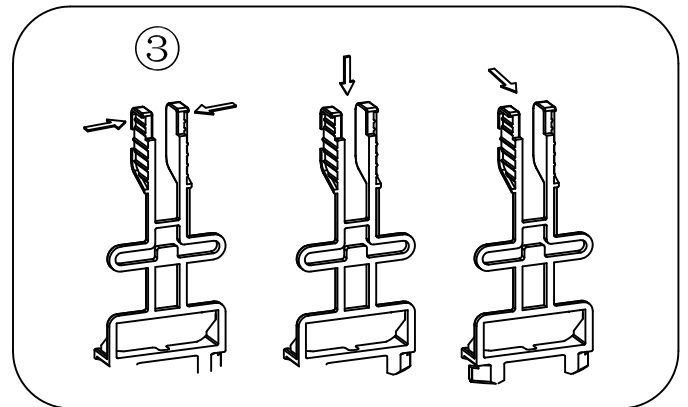
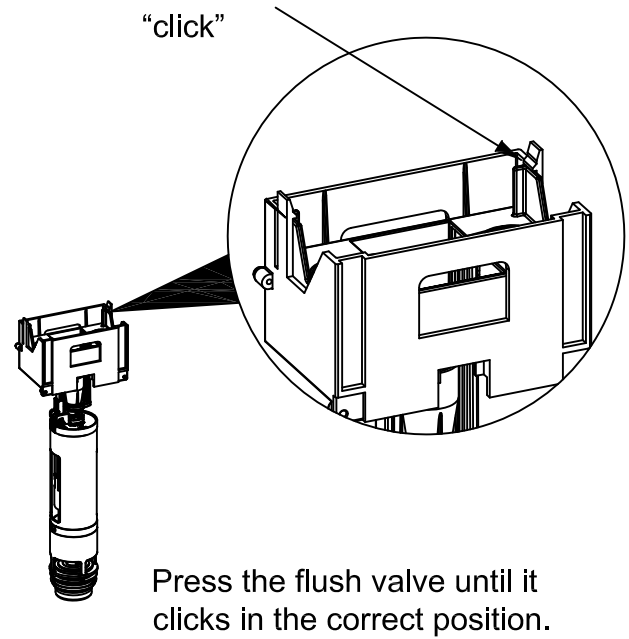

Re-install the top glass cover.